



Controlling Your Comfort Room by Room

Static Pressure Adjustable Dampers

Model: SPAD. GEN 3

The Static Pressure Adjustable Damper, Model SPAD, is a single blade, counter-balancing spring damper, that operates on air pressure in order to control the flow of by-pass air on a zoned system. The SPAD utilizes an adjustable knob/blade to maintain the correct amount of pressure in the duct system. The SPAD allows for setpoints between 0.3 inches W.C. of pressure to 0.8 inch W.C.

As zone dampers close off air to a number of zones, the supply air pressure in the duct system will increase. This increase in air pressure can increase the noise level and reduce the flow of conditioned air through the HVAC Unit. The SPAD operates similar to the SPRD in that it helps maintain a constant air pressure in the duct system. However, the SPAD utilizes minimum setpoints for the blade to respond to air pressure. This reduces buildup of pressure within the supply and also helps reduce the noise that is caused by these high air pressures and velocities, as well as maintains a constant volume of air (CFM) through the duct system. Maintaining a constant volume of air through the HVAC System keeps the efficiency of the system at its maximum.

The SPAD is available in round sizes only. The chart below lists the available sizes of SPADs and their recommended CFM capacities.

Round Sizes

Size (Diameter)	CFM	Size (Diameter)	CFM
8"	400	14"	1,600
10"	750		
12"	1,000		

Calculating By-Pass Air Requirements

Determining the need for by-pass air and the size of the SPAD required is very simple. It can be very simply calculated by knowing the total CFM capacity of the HVAC unit (T_{CFM}) and subtracting the CFM capacity of the smallest zone (S_{CFM}) will equal the CFM of air required to be by-passed (B_{CFM}).

$$T_{CFM} - S_{CFM} = B_{CFM}$$

Total CFM Smallest Zone CFM By-Pass CFM

Once the by-pass amount of air is known, use the chart above to select an appropriately sized by-pass damper. It is always recommended to have a larger size by-pass than having one that is too small. It is much easier to reduce by-pass air through the damper or close it off than having to increase the size of the by-pass duct and/or damper.

Location

Selecting a location to place the SPAD is very important for overall system operation. Ideally the best place for the SPAD is as far away from the air handler as possible and before any zone dampers. In an extended plenum application where zones come off the side of the main trunk, the end of the extended plenum is the ideal situation.

In most residential applications, however, the zone dampers are right at the plenum of the air handler. In this application the only location for the SPAD is at the plenum. In this application, especially when the SPAD is ducted to the return, it is recommended that a freeze protection, Model AFC, be used as well as the supply air sensors with the zoning panel to protect the equipment from overheating or cooling due to the return by-pass.



Installation

The SPADs are easily installed in-line of any round duct, with the blade already enclosed in a 10" length of duct. The SPAD is just like any typical length of round rigid duct, with a crimped end in the direction of the air flow.

Place the flat collar end of the damper over the crimped end of the take-off or rigid metal duct. Insert crimped end of round damper into un-crimped end of rigid round duct and secure with sheet metal screws. When using flexible duct, slip duct over end of the round damper and secure with duct straps (not provided).

Most SPAD installations are typically in horizontal ducts where the SPAD control blade will close vertically. The SPAD can also be installed in vertical ducts.

To adjust the SPAD, all zone dampers must first be open and the fan operating. When all dampers are open, the knob to the SPAD should be positioned in the desired minimum setpoint for pressure. Air will flow past the blade, limiting the buildup of pressure within the supply plenum. This ultimately will result in less noise normally caused by the damper blade constantly moving.

Dimensional Drawing – SPAD Gear

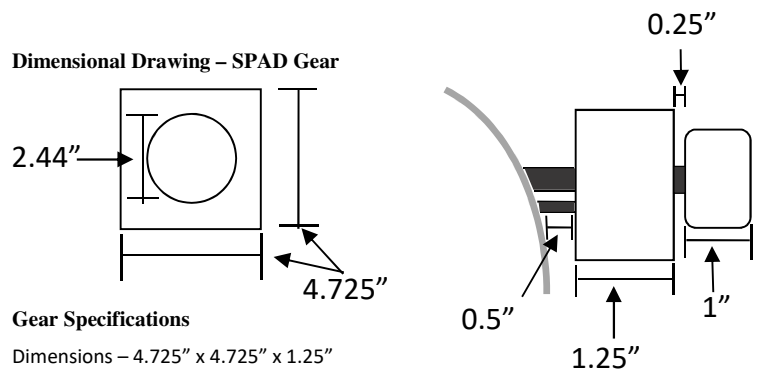

Gear Specifications

Dimensions – 4.725" x 4.725" x 1.25"

Temperature Rating – 0°F to 180°F Operating, -20°F to 190°F Storage

Humidity – 5% to 95% Non-Condensing

Static Pressure – Maximum 0.8" W.C.