

Static Pressure Regulating Dampers Model SPRD

Barometric By-Pass Dampers

The Static Pressure Regulating Dampers, Model SPRD, are barometric relief dampers used to by-pass excess air pressure on zoned systems. The SPRDs automatically respond to the air pressure in duct as the various zone dampers open and close.

As zone dampers close off air to a number of zones, the supply air pressure in the duct system will increase. This increase in air pressure can increase the noise level and reduce the flow of conditioned air through the HVAC Unit. Using the SPRD solves this by automatically compensating for the excess air pressure by opening on the increased pressure and relieving the excess air. The SPRD helps maintain a constant air pressure in the duct system. This reduces noise that is caused by high air pressures and velocities, as well as maintains a constant volume of air (CFM) through the duct system. Maintaining a constant volume of air through the HVAC System keeps the efficiency of the system at its maximum.

The SPRD is available in square/rectangular and round sizes. The chart below lists the available sizes of SPRDs and their recommended CFM capacities.

Square and Rectangular Sizes

Size	CFM	Size	CFM
12" x 8"	800	20" x 8"	1,600
12" x 10"	1,000	20" x 10"	2,000
12" x 12"	1,400	20" x 12"	2,400

Round Sizes

Size (Diameter)	CFM	Size (Diameter)	CFM
7"	200	12"	1,000
8"	400	14"	1,600
9"	600	16"	2,400
10"	750	18"	3,000

Calculating By-Pass Air Requirements

Determining the need for by-pass air and the size of the SPRD required is very simple. It can be very simply calculated by knowing the total CFM capacity of the HVAC unit (T_{CFM}) and subtracting the CFM capacity of the smallest zone (S_{CFM}) will equal the CFM of air required to be by-passed (B_{CFM}).

$$T_{CFM} - S_{CFM} = B_{CFM}$$

Total CFM Smallest Zone CFM By-Pass CFM

Once the by-pass amount of air is known, use the chart above to select an appropriately sized by-pass damper. It is always recommended to have a larger size by-pass than having one that is too small. It is much easier to reduce by-pass air through the damper or close it off than having to increase the size of the by-pass duct and/or damper.

Location

Selecting a location to place the SPRD is very important for overall system operation. Ideally the best place for the SPRD is as far away from the air handler as possible and before any zone dampers. In an extended plenum application where zones come of the side of the main trunk, the end of the extended plenum is the ideal situation.

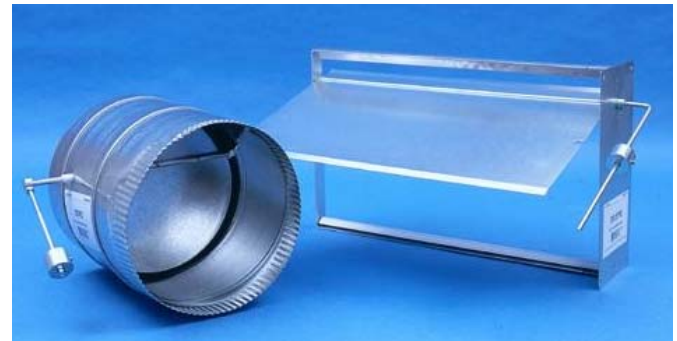

In most residential applications however the zone dampers are right at the plenum of the air handler. In this application the only location for the SPRD is at the plenum. In this application, especially when the SPRD is ducted to the return, it is recommended that a freeze protection, Model AFC, be used as well as the supply air sensors with the zoning panel to protect the equipment from overheating or cooling due to the return by-pass.

Installation

The SPRDs are easily installed into any square or rectangular duct by simply cutting a 2 to 3 inch slot on the side of the duct and inserting the SPRD. The square/rectangular SPRD has a 5" wide end plate to cover over the opening. There are six pre-punched holes for self-tapping screws (provided) to be used to secure the damper to the duct.

The round SPRDs are also installed in-line of the duct, however the blade is already enclosed in a 10" length of duct. The SPRD is just like any typical length of round rigid duct, with a crimped end in the direction of the air flow.

Most SPRD installations are typically in horizontal ducts where the SPRD control blade will close vertically. The SPRD can also be installed in vertical ducts as well, however the counter balanced, weighted arm must be adjusted to offset the weight of the blade. See installation instructions for further information on this application.

The SPRD has a weighted control arm that counter balances the weight of the damper blade. The weight adds pressure to the blade to control the amount of air by-passed. The weight can be adjusted up or down on the arm depending upon the amount of air to be by-passed. In addition to the adjustment of the weight the arm can also be moved in order to add leverage for the weight to push against the blade to add more resistance.

To adjust the SPRD, first all zones dampers must be open and the fan operating. When all dampers are open the SPRD should be closed. In some instances the damper may be open slightly, especially when the SPRD is installed as a true by-pass between the supply and return ducts. This occurs frequently when the damper is closest to the plenum.

After observing the SPRD position, begin closing the larger zone dampers one by one, until only the smallest zone damper is open. The SPRD will most likely be full open at this point. If not, adjust the weight and the arm to provide the correct amount of pressure, prior to the point of increasing the static too much where there will be a reduction in the airflow and air noise becomes an issue.

Dimensional Drawing – Round SPRD

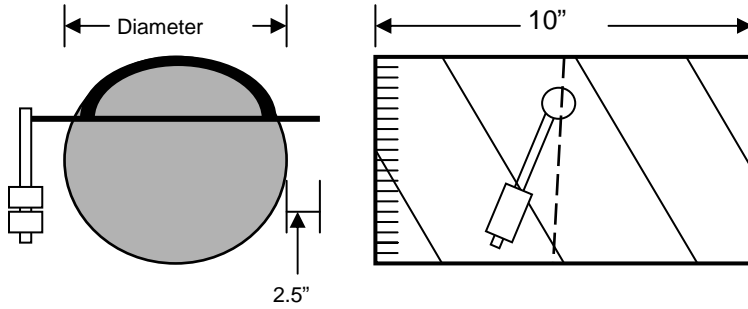

Damper Specifications

Construction – 22 Gauge Galvanized Steel

Dimensions – 5", 6", 7", 8", 9", 10", 12", 14", 16", 18", 20" Diameters.

Temperature Rating - 0°F to 180°F Operating, -20°F to 140°F Storage

Humidity – 5% to 95% Non-Condensing

Static Pressure – Maximum 0.5" W.C.

Dimensional Drawing – Square and Rectangular SPRD

Damper Specifications

Construction – 22 Gauge Zinc Plated Steel Steel

Dimensions – 12"x8", 12"x10", 12"x12", 20"x8", 20"x10", 20"x12"

Temperature Rating - 0°F to 180°F Operating, -20°F to 140°F Storage

Humidity – 5% to 95% Non-Condensing

Static Pressure – Maximum 0.5" W.C.

