



Automatic Opposed Blade Dampers

Models AOBD, AOBM and IOBD

The Automatic Opposed Blade Dampers are a series of aluminum air control dampers that insert into any duct. These opposed blades dampers can be ordered in side mount, bottom mount and internal mount of the motor depending upon the accessibility of the duct.

Each damper is constructed from extruded anodized aluminum and has a stainless steel draw bar that operates the damper blades and brass and zinc plated linkage for corrosion resistance and long life. The patented gear design and counter balanced opposed blade damper design provides smooth long lasting operation. The 24 Volt AC, power open and power closed motor is also designed for long life and is only powered for 30 seconds while the motor moves between open and closed.

The AOBD series were the first self-contained motorized dampers for air control. The industry standard or over 40 years and with hundreds of thousands installed, the AOBD series has been the standard which others are measured.

The AOBD series is available in 3 mounting styles. The AOBD is a "side" mount damper with the motor and end plate mounted on the shorter dimension and is typically inserted into the side of a duct. This duct is typically horizontal and is wider than high. The opposite version of the side mount is the AOBM, bottom mount. This damper's motor and end plate are on the longer dimension. The AOBM is designed to be inserted into the bottom or top of a horizontal duct. The third model is the IOBD, internal mount. The IOBD has no end plate and the motor is mounted on a bracket within the confines of the dimensions of the damper. The IOBD is typically inserted in the opening of a duct, typically near the outlet register or diffuser. Mounting tabs are used to secure the damper to the inside of the duct.

The AOBD and AOBM are easily installed by cutting a 3" slot in the side, bottom or top of the duct, inserting the damper and securing the end plate with self-tapping screws (supplied) through the pre-punched holes in the end plate.

The application for these dampers are many and range from controlling temperatures for zone control to outside air to just switching the flow of air between low and high returns between seasons and/or solar applications. These dampers require a simple single pole-double throw switch to drive open and closed. The types of controllers most often used are thermostats however the dampers can also be controlled by manual or automatic switches, timers and/or relay contacts.

The thin profile design of the AOBDs make this the thinnest motorized damper in the industry and the IOBD is perfect for controlling the air in many thru-wall applications.



The MST motor powers the damper open and closed and is designed to operate in all weather conditions. The AOBD is recommended for low pressure duct systems, less than 0.75" S.P. For higher pressure systems use the Comfortron™ series of dampers.

The AOBD Series is available in even sizes from 6"x4" to 30"x14" and 20"x20" square. The bottom mount dampers are only available from 6"x6" to 14"x24". For larger sizes use the Comfortron™ series of dampers.

SPECIFICATIONS

Construction – Anodized Extruded Aluminum frame and blades, Stainless steel draw bar and nickel plated linkage and brass hardware.

Ambient Temperature - -55°F (-48°C) to 200°F (93°C)

Electrical – 24 Volts AC 50/60 Hz, 6 Watts, Power Open-Power Closed Damper Motor.

Connections – Screw Terminals

Motor Timing – 30 Seconds Open and Closed

Static Pressure – Max 0.75"W.C.

Dimensions – Listed Size less 1/8" Nominal

Dimensional Drawings

Installation Drawings

AOBD

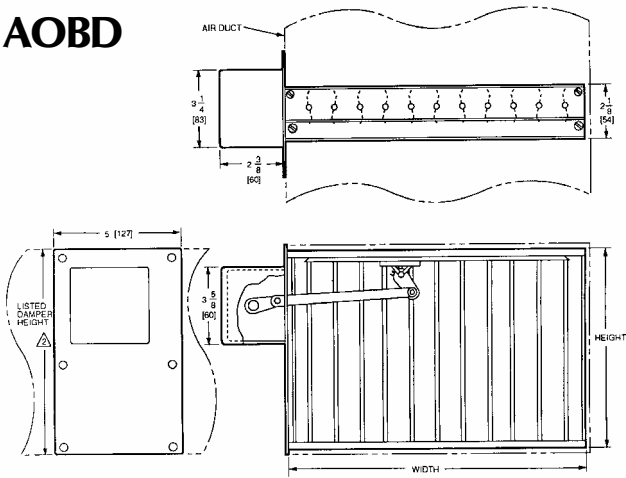

Cut a 3" slot in the side of the duct, slide the damper in and secure with self-tapping screws provided.

AOBM

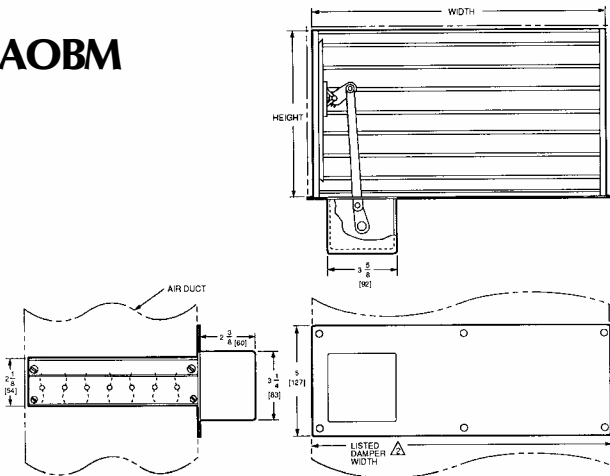

Cut a 3" slot in the bottom of the duct, slide the damper in and secure with self-tapping screws provided.

IOBD

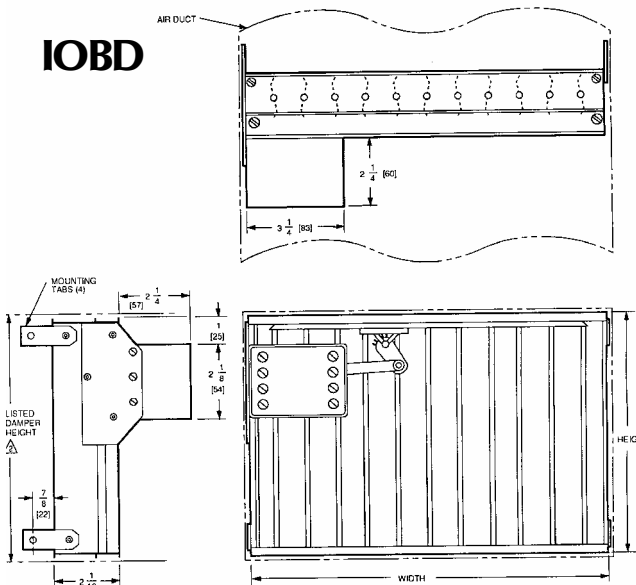

Wire damper motor first snaking wire thru duct and then insert damper into duct opening and secure with self-tapping screws (provided) thru mounting tabs.